

NT 02011

VKMA/C 02200 -  
VKMA/C 02201 -  
VKMA/C 02202 -  
VKMA/C 02203

Fiat / Lancia

VKMA 02200



VKMC 02200



VKMA 02201



VKMC 02201



VKMA 02202



VKMC 02202



VKMA 02203



VKMC 02203



A



(9): Tension tools  
(ref. 1060745100 +  
1060745300 or ref.  
1860745100 +  
1860745300).

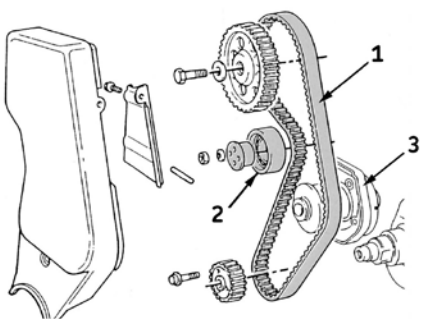

#### Removal

- 1) Disconnect the battery according to the vehicle manufacturing guidelines.
- 2) Prepare the vehicle for the timing replacement according to the vehicle manufacturing guidelines.
- 3) Position cylinder No.1 at TDC, in this position, mark (4) on the camshaft sprocket must be aligned with the cylinder head gasket face (5) and mark (6) on the crankshaft sprocket with that on the oil pump housing (7) (Fig. B).
- 4) Untighten fastening nut (8) and push in tension roller (2) to untighten and remove timing belt (1) (Fig. B).
- 5) Remove the tensioner roller (2).
- 6) **Removing the water pump (VKMC 02200/02201):** firstly bleed the cooling circuit, check it is clean, and clean if required; secondly fully loosen the water pump (3) fastening bolts (11) and remove the pump (Fig. A).

B

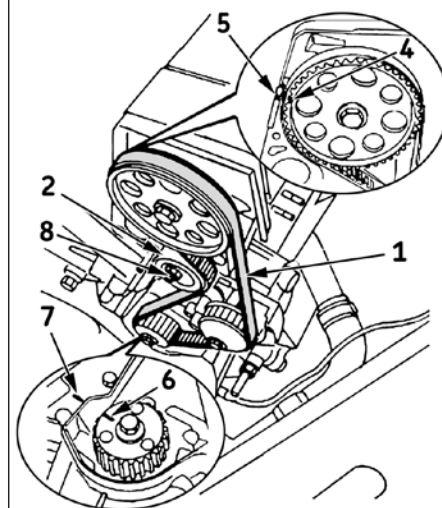

Install Confidence



## Refitting

**Caution!** Clean the bearing surfaces of the rollers.

- 7) **Refitting the water pump:** Firstly, fit the new water pump (3), apply the torque **10 Nm** to the waterpump bolts (11); then check that the water pump pulley runs properly, and has no hard or locking spots.
- 8) Fit the new tension roller (2) in position.
- 9) Fit the new timing belt (1) in the following order: camshaft sprocket, water pump pinion, crankshaft and tensioner roller (2) (Fig. A).
- 10) Check the alignment of the timing marks (4) and (6) (Fig. B).
- 11) Fit tool (9) horizontally on the tensioner roller (2), position the weight at **65 mm** on the ruler (Fig. C and D).
- 12) Turn the crankshaft by **two turns** in the normal running direction of the engine up to TDC, check the alignment of the timing marks (4) with (5) and (6) with (7) (Fig. B).
- 13) Tighten the nut (8) (Fig. B) of tension roller (2) to a torque of **28 Nm**.
- 14) Remove tool (9) with the weight (10) (Fig. C and D).
- 15) Check the tension of the timing belt (1) according to manufacturer recommendations. If required, readjust the belt tension using the tensioner roller (2).
- 16) Refit and tighten the crankshaft pulley.
- 17) Refit the elements removed in reverse order to removal.
- 18) Fill the cooling circuit with the permanent fluid recommended.
- 19) Check the circuit's leak-tightness when the engine reaches its running temperature and secure the level of coolant when the engine is at ambient temperature (20 °C).

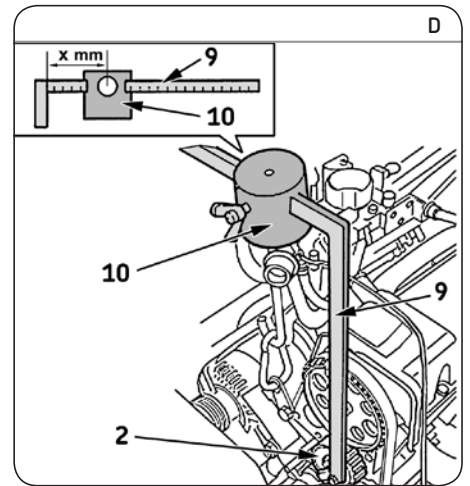
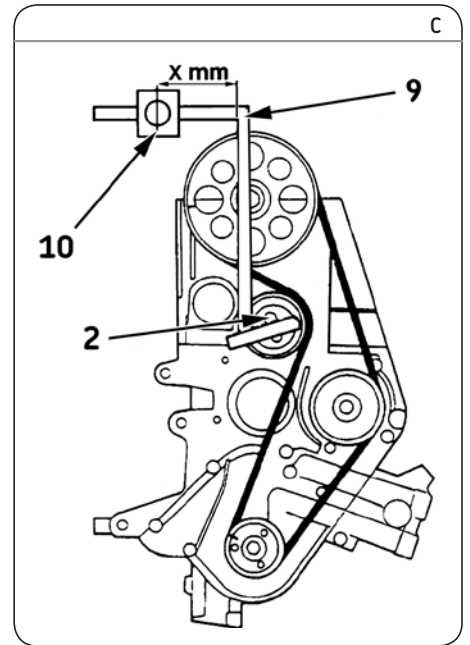

**Notice: Always follow the vehicle manufacturer instructions when working on the engine.** The SKF KITS are designed for the automotive repair professional and must be fitted using tooling used by these professionals. These instructions are to be used as a guideline only. This document is the exclusive property of SKF. Any representation, partial or full reproduction, is forbidden without prior written consent from SKF.

© SKF is a registered trademark of the SKF Group.

© SKF Group 2014

The contents of this publication are the copyright of the publisher and may not be reproduced (even extracts) unless prior written permission is granted. Every care has been taken to ensure the accuracy of the information contained in this publication but no liability can be accepted for any loss or damage whether direct, indirect or consequential arising out of the use of the information contained herein. Any cost savings and revenue increases in this publication are based on results experienced by SKF customers and do not constitute a guarantee that any future results will be the same.

PUB 80/11 15021 EN · September 2014

